

# Active Headsets

INCORPORATED

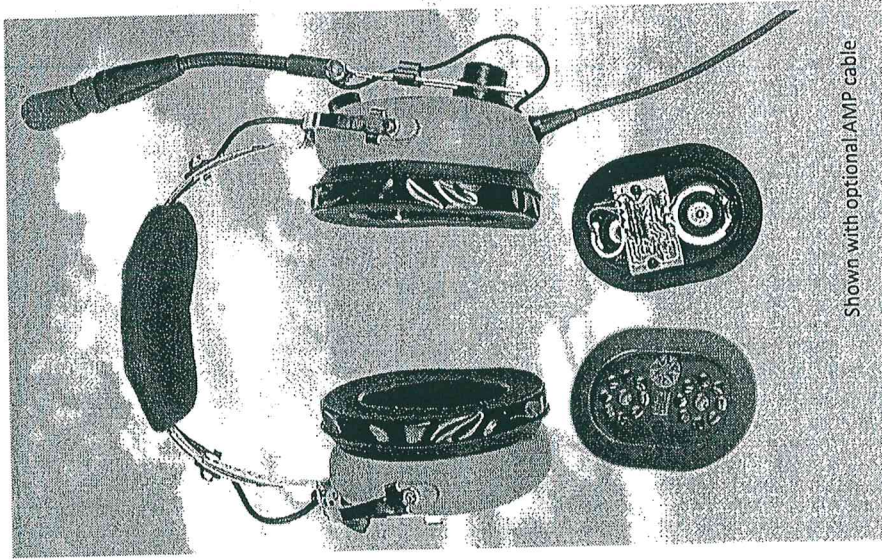

Shown with optional AMP cable

Active Noise Reduction Module  
Installation and Operating Instructions

# INDEX

I.	Parts List & Tools Required.....	1
I.	Remove existing speakers.....	2
III.	Install power cable.....	4
IV.	Install new crossover cable.....	4
V.	Review the color wiring diagram.....	6
VI.	About soldering.....	6
VII.	Soldering the wiring harness.....	8
	Install insulation.....	10
	Attach wiring to modules	
VIII.	Test & Close headset	
	Operating Instructions.....	11
	Supplemental Instructions-Flightcom 4DX & 5DX.....	13
	Warranty Information.....	back cover

## Parts List

Check to see you have received all materials

- 1 pair modules (2 modules) - marked R & L. Each module contains an anr speaker, audio speaker, microphone and circuit board.
- 1 9v battery case - Sliding door permits easy access.
- 1 power cable - 60 inch, 2 conductor (red9+ black-ground-) w/ rubber grommet.
- 1 crossover cable - 4 conductor cable, 33" length.
- 1 zip-loc bag of installation materials: solder, 28ga wire, 3/32" shrink-wrap, tie-wraps.
- 2 fabric pads (black/white oval).

\*Not included if optional AMP cable is purchased

## Tools Needed

1. Fine tip soldering tool (20 watt or less)
2. Power drill and 1/8", 3/16" and 1/4"bits (not needed if AMP cable is being installed)
3. Small wire cutters
4. Small screwdriver set
5. Damp sponge- to clean solder tip
6. Butane lighter-to heat shrink wrap
7. Continuity Tester (optional)-very helpful to confirm & identify wire leads

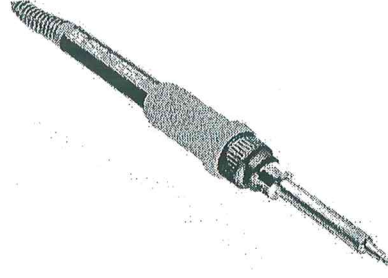
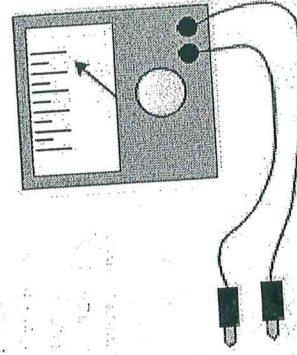

## Caution

Read these instructions completely before beginning the installation. The anr modules are finely tuned & require that installation be performed strictly in accordance with this manual. Deviations from the instructions contained herein will result in a System malfunction. Purchaser assumes all risks arising from an improper installation.

This product is intended for "self" installation into your headset and requires reasonable skill in the use of a soldering tool but a minimal understanding of electronics. If you question your ability to perform the installation, you are advised to take this unit & your headset to the nearest electronic technician, or ship them to **HEADSETS, INC.** for a factory installation. Any radio/TV or avionics technician should be able to install the modules in 2 hours.

## I. Remove existing speakers

Remove the earseals from each earcup. The earseals stretch around the earcup flange & are easy to remove.

Inside each earcup, surrounding the speaker, you will find 2 or 3 pieces of foam packing. Use tweezers to remove the top piece of foam (usually donut shaped). You will see 2 screws which hold each speaker in place. Remove the 2 screws. The speakers can now be lifted from the earcups. Disconnect the 2 speaker wires from the speaker. Now remove the remaining piece of foam insulation.

**Identify & mark these 2 wires audio+ and audio-.** In 98% of headsets the wire passing thru the volume control will be the audio (+). The other wire is, of course, the audio (-). [exception: Flightcom 413X and 5DX sets, see supplemental instructions on page 13] If you have any doubt about the identity of audio+ and audio- you should use a continuity tester (circuit tester) and refer to the drawing of audio plugs on color drawing A.

When removing the original foam insulation, be careful of the volume control terminals. The terminals can be very brittle on David Clark models, so avoid bending. Leave the earcups empty while splicing the wiring. The new foam insulation pieces will be installed after the wiring job is complete.

**Insert a module into each earcup to insure that a fit can be made.**

Generally, any make of headset which is similar to the David Clark "H-10 series" will accept the anr module. David Clark model H-10-13.4 has earcups which are shallower than most, and the left side requires extra attention to tucking wires away when finally closing L earcup.

**IMPORTANT:** it is mandatory that you use "silicone gel" type earseals. The original earseals (dry or liquid filled) are not as airtight as gel seals, and in addition do not dampen sound and vibration as effectively. The result is that the anr units will greatly underperform (20-50%) and will be more likely to malfunction. Most brands of gel earseals are compatible with the anr modules.

**Fig. 1**  
Removal of insulation and original audio speaker

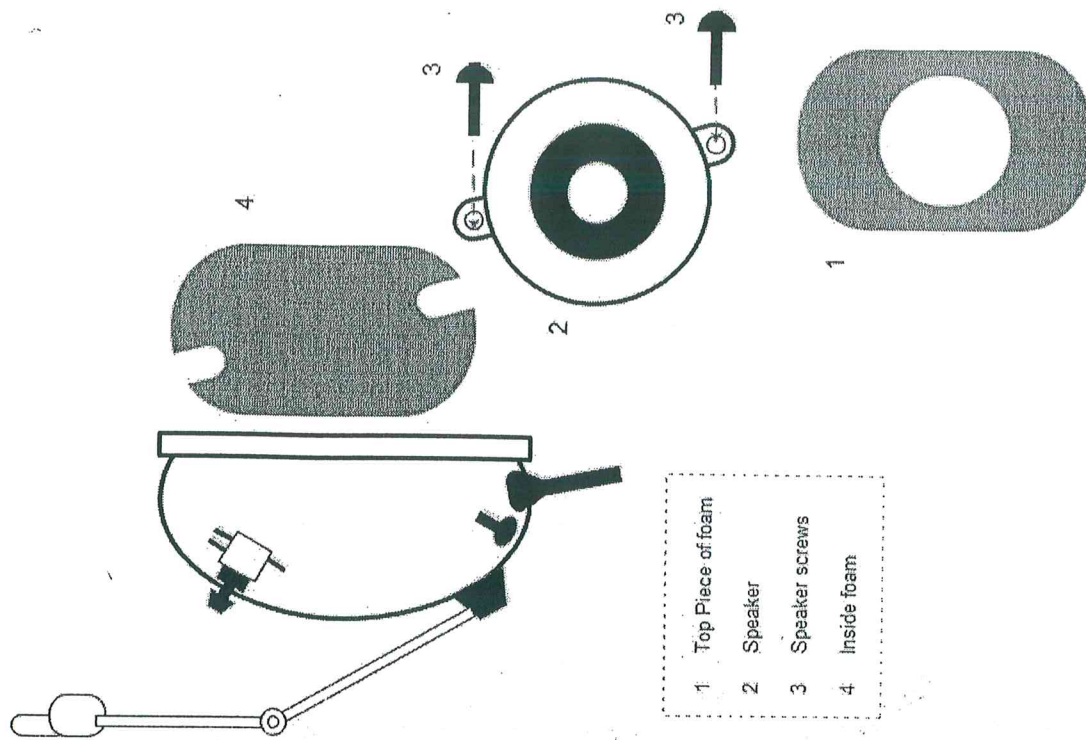

Disregard sections II & IV if you purchased the optional AMP cable, and do not drill a hole in the left earcup. Instead, refer to the instruction sheet supplied with the AMP cable.

## II. Install power cable or new AMP cable

Using a pen or marker, mark a point at the base of the left earcup to drill a 1/4 inch hole to permit the power cable to enter the left earcup.

1. Check inside the earcup to be sure you are not going to hit an obstruction (i.e., the Post where original speaker was mounted).
2. Drill a 1/8" pilot hole, and then enlarge to 3/16", and then 1/4". Remove all debris. Install the rubber grommet, using a small screw driver to ensure it is fully seated inside the earcup.
3. Feed the power cable through the grommet and place a tie wrap on the cable about 3 inches from the upper end of the cable. Remove the outer insulation (black casing) above the tie-wrap. Next, remove/cut the shield (bare wire) from the cable.
4. After soldering is completed, pull down on the cable to seat the tie-wrap, pulling slowly so you don't unseat the grommet.
5. After the power cable is installed, attach it to the main cable using the black 3" tie-wraps. Do not over tighten tie-wraps or the cable(s) may break prematurely. Place a tie-wrap every 10 or 12 inches along the cables. Trim off the excess tie-wrap length. The 2 cables will quickly tangle if they are not tie-wrapped together.

## III. Install new crossover cable

The crossover cable is the cable that runs overhead from your left earcup to your right earcup.

Using wire cutters, remove your existing cable and replace it with the new crossover cable provided. The new cable should easily slide through and replace the old cable.

Headsets with PTT (push to talk) switch in right earcup must use a 5 conductor crossover cable to retain the use of PTT function. These headsets are the AvComm model AC-454, AC-800, AC-900, and Softcom model C-10 and C-60.

Fig. 2

After installation of power cable and crossover cable but before reassembly.

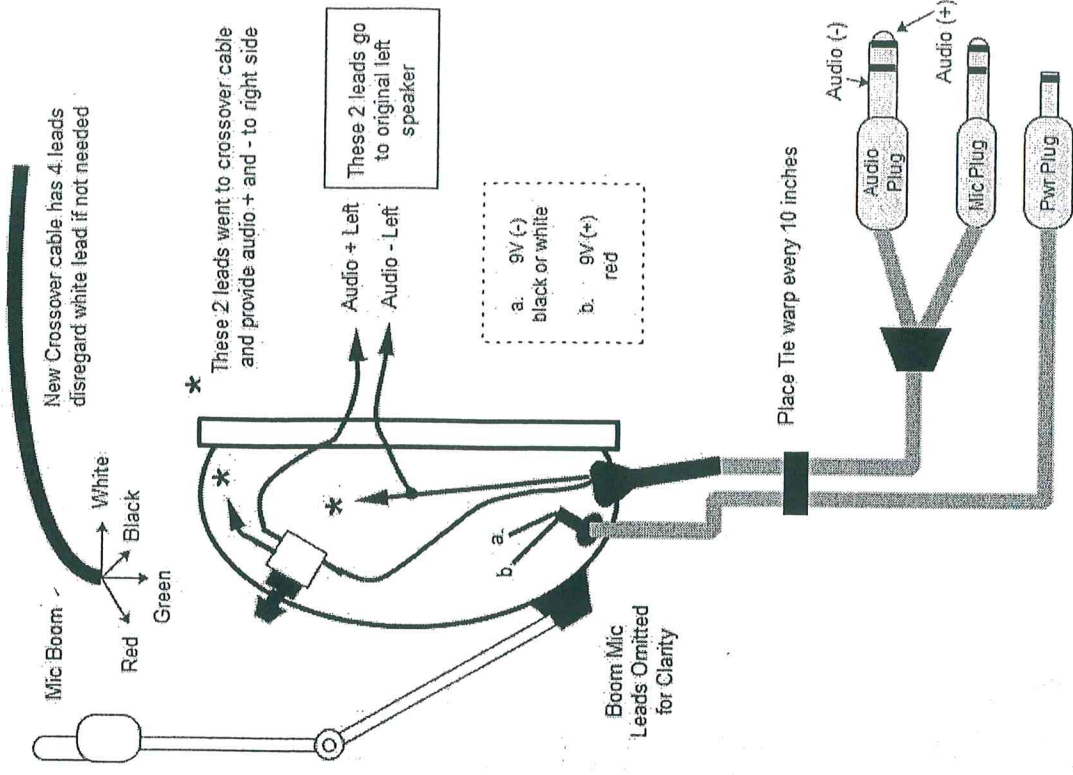

## Disregard section IV if installing AMP cable.

### IV. Review the color wiring diagram

Refer to Figures A-E on the color wiring diagram and to Figure 3 at right.

1. Although most installations will follow Figures A and 3, there are 4 other color diagrams showing the correct method to wire various headsets (see fig. B, C, D & E). Choose the one that matches your headset type (i.e., stereo or mono; location and number of volume controls). Please call if you have any questions.
2. The only two wires you must identify are audio+ and audio-. These were the two wires attached to the original audio speakers and should have been marked when the speakers were removed. If uncertain which is audio+ and which is audio-, use a continuity tester and refer to the drawing of audio plugs located directly above figure A. The color wiring diagram represents the wiring to be installed, and cannot be used to identify the original audio (+) and audio (-) wires found in your headset.
3. Determine whether your headset is mono or stereo by comparing your audio plug to the plugs pictured on the color wiring diagram.

If your headset is mono, the audio+ usually passes thru the volume control as per color diagram "A". The ground- wire will usually be black or white. Identify can easily be confirmed with a continuity tester applied to the audio plug and the unknown wire. The tip of the audio plug is always audio (+). The base of the audio plug is always audio (-).

If your headset is stereo, audio+ will consist of 2 leads, each passing thru its own volume control, as shown in Fig. D.

### V. About soldering

If you are not experienced with a fine tip soldering tool, a few minutes of practice will result in a cleaner wiring job. Do not use a large soldering tool for this installation.

When soldering 2 wires together, first twist each bare wire and then trim to leave only 1/8" of bare wire exposed. Heat the bare wire ends with a hot iron and "tin" wire ends by melting solder into the wire until it is "wet" with solder. The rosin core of the solder acts to facilitate the wetting of the wire braid, so melt the solder directly into the wire to be tinned, and also to the tip of the (clean) tool. Clean the solder tool tip of excess solder & rosin by rubbing it on a damp sponge or towel.

Wire ends being soldered should each have only 1/8" to 1/4" exposed. When both ends of the wires have been tinned, hold the two ends side by side and heat until they fuse together.

Cover the exposed splice with shrink wrap. Gently heat the shrink wrap for 1-2 seconds with a flame (butane lighter works best). Keep the flame away from the wires to avoid damaging the insulation.

Use the 28 ga. wire (provided) when constructing the wiring harness and attaching to the p.c. board. Do not use heavier gage wire from the original headset to attach to the p.c. boards or the final installation will be more difficult (i.e., tucking wires & closing unit). Using the flexible 28 ga. wire (and removing excess lengths of original wire) will result in a more professional installation.

Use only electronic type solder (has no acid). A fine point soldering iron is available at most hardware stores for under \$10. Practice soldering. Re-work any splices if not pleased with initial work, or if you see that the wiring job can be improved.

Fig. 3

Completed wiring on mono headset, except for hook-up to crossover cable.

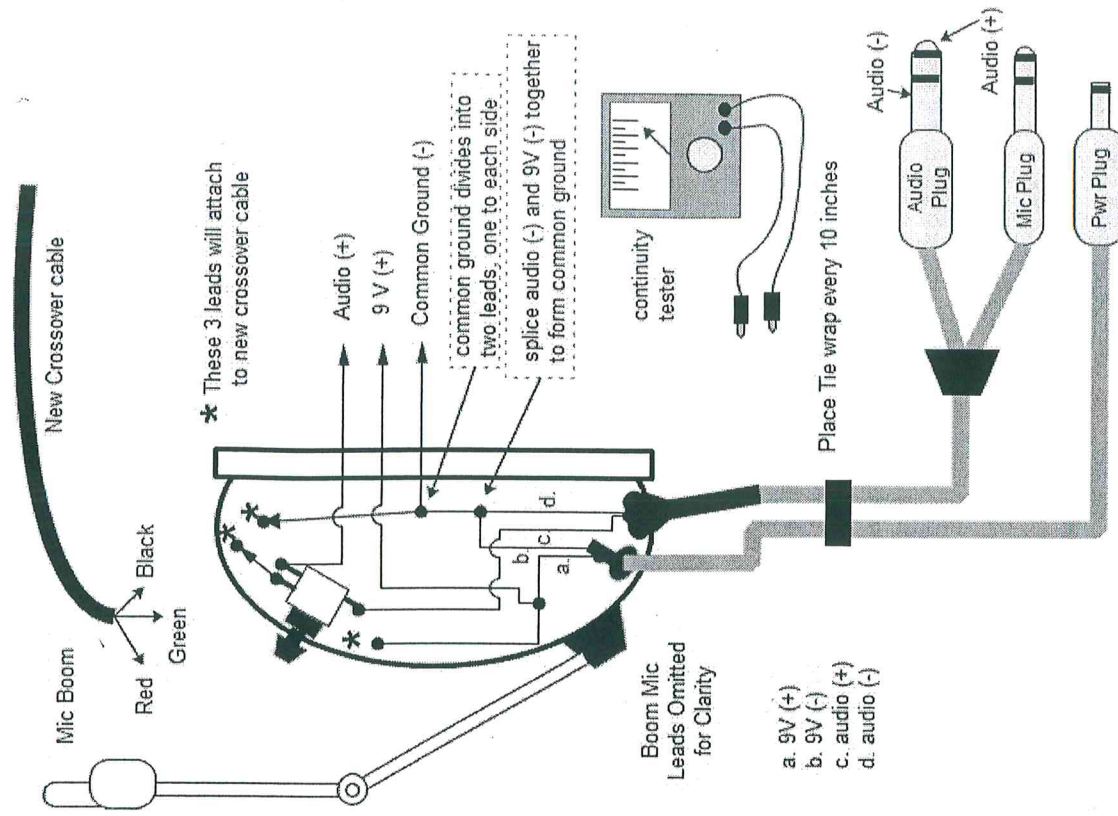

## VI. Soldering the wiring harness

All of the splicing takes place in the left earcup, unless a volume control is located in the right earcup. Don't solder any wires directly to the modules printed circuit boards until the wiring harness is complete and the headset is ready to test and close (step VII).

Disregard the following sections A and B if the optional AMP cable is being installed.

**A. Audio cable leads:** the original audio cable enters the left earcup. It carries at least 4 conductors: 1. audio+ 2. audio- 3. mic+ 4. mic-

1. audio (+) wire is the wire that passes thru the volume control, thereafter dividing into 2 wires to form R & L audio+.

*Exception: Flightcom model 4DX and SDX- See supplemental instructions on page 13 and disregard the remainder of this section "A".*

Attach one of these 2 to the crossover cable/green wire. Let the other hang loose in the left earcup. Each earcup now has 1 green wire to attach to a module in step VII.

2. audio (-) wire should be tied in with the 9v (-) wire to form a common ground (also described in #2 below). This common ground wire should now be spliced into 2 black wires and one of these 2 should attach to the crossover cable/black wire. Let the other hang loose in the left earcup. Each earcup now has 1 black wire to attach to a module in step VII.

3. & 4. mic+ and mic- wires can be identified by tracing them to & from the boom mic. Do not tie into the mic circuit in any manner.

**B. Power cable leads:** the new power cable you installed has 2 wires:

1. Red wire: 9v+ should be spliced into 2 red wires, per the color diagram. One will then attach to the crossover cable/red wire. Let the other red wire hang loose in the left earcup. Each earcup now has 1 red wire to attach to a module in step VII.

2. Black or white wire: As stated above the 9v- wire and the audio- wire must be soldered together in order to create a common ground. After 9v- and audio- merge into one, the common ground they form should then be divided (spliced) into 2 leads. Attach one of these to the crossover cable/black. Let the other hang loose in the left earcup. Each earcup now has one common ground wire to attach to a module in step VII.

**Fig. 4**  
Wiring to module.

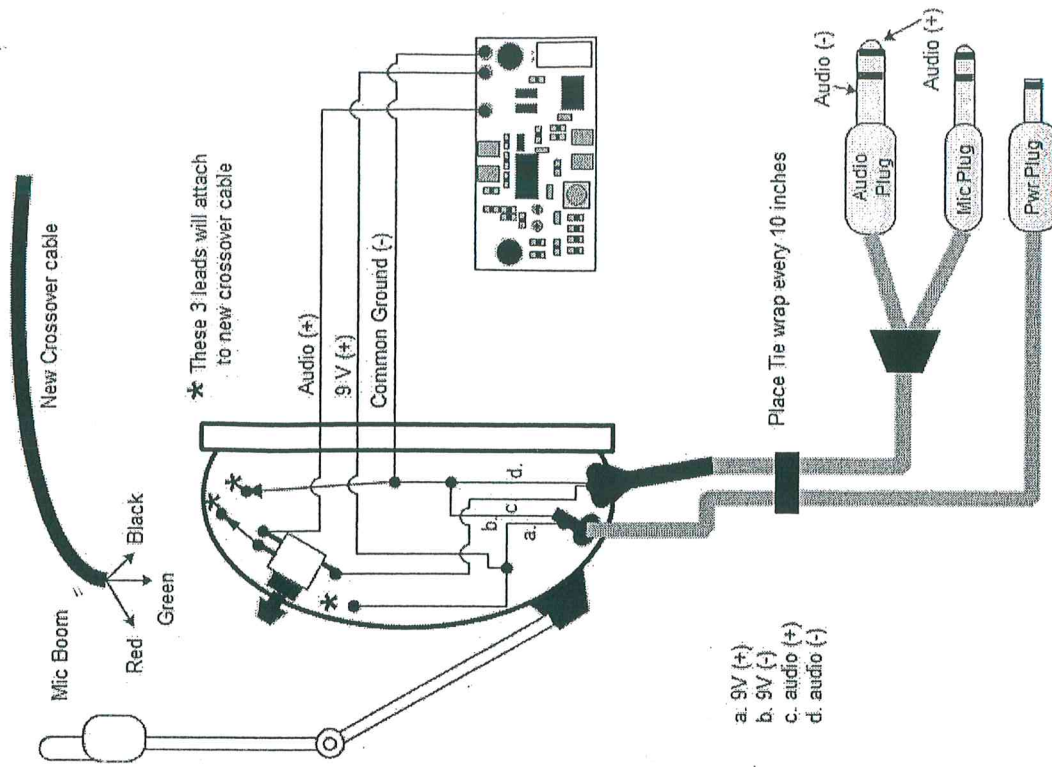

Installing Insulation

Before soldering any wiring to the modules, install the gray foam insulation provided. The cross-shaped foam pieces will roughly conform to the shape of the inside of the cup. Make a slit in the foam pieces to allow the red, black & green wires to pass through and attach to the modules. It may be necessary to cut a slit to fit the insulation around the posts (original speaker mounts) or the volume control.

Attach wiring to modules

Melt a small spot of solder onto each of the 3 attach points located on the corner of each module's circuit board. Do not insert the wires into the holes as it is preferred that the wires lay flat. Carefully solder the 3 wires to the circuit boards according to the color diagram. If you wear your boom mic on your left, install the L module into that earcup. If you wear your boom mic on your right, install the R module in to that earcup (see operating instructions, #2).

Test & Close Headset

Arrange the wiring as neatly as possible. Tuck wiring away where possible, and fit the modules into the earcups. They should fit easily into the earcups and not tend to push out. Insure the modules are positioned correctly. See VIII (2).

*IMPORTANT: 2 black/white oval pieces of fabric are provided with each set. This material is intended to keep dirt & debris out of the speaker elements and to acoustically dampen the anr modules. One should be placed inside each anr module, covering the speaker grill holes & the microphones. Use of the fabric pads is mandatory. Failure to use these may result in feedback (squealing). If the pads are lost or become soiled, call for a free set of replacements.*

VIII. Operating instructions

1. As previously stated, silicone gel earseals are required for proper operation of this unit. Other items, such as cloth ear covers are not airtight and will cause significant loss of anr strength and will reduce battery life. Extra-thick earseals (i.e., 1.5 inch thick Oregon Aero Soft Seal) will cause extreme loss of anr strength because of the additional volume they create inside the module/ear seal assembly. Oregon Aero does have a 3/4" thick version of their Soft Seal which can be used with the anr module.
2. Please note that each module is labeled R or L. Next to this is a small electret microphone housed in a grommet. Your headset must be always be worn with the left module on your left side and right module on your right side. This insures that the microphones will be located in the proper position (forward part of each cavity surrounding the ear). They must remain in this position. The practical result is that the position of the "boom-mic" is now fixed (right or left). These instructions assume you wear the boom mic on the left. If you wish to wear the boom mic on the right, you should install the right module in to the earcup with the boom mic.
3. A standard aircraft radio is all that is required to power the audio portion of the anr modules. However, an audio signal is not necessary for the active noise reduction circuit to operate. Supplying 9V to the modules will activate the noise cancelling System. If audio reception or transmission is "scratchy", check for tarnished brass tips on audio or mic plug. Polish if necessary.
4. Because the anr modules boost the audio by about 2db, volume levels on your headset should be pre-set at less than maximum. Then, to further adjust the volume, use either the intercom volume control or the headset volume control. However, setting your headset volume control too low may cause you to increase the intercom volume to a point where the intercom is over driven & distortion may result.
5. In cold conditions (below 32 F. OAT) remove the headset from the aircraft after each flight. If headset becomes cold soaked it is more subject to moisture condensation inside the earcups. Although summertime cabin temperatures will not damage or degrade the unit, the battery case can warp if left in direct sunlight.
6. Operation under cold conditions (below 40 degrees F. cabin temp) can result in moisture condensation inside the headset causing temporary malfunction. Allow unit to warm. & dry before resuming use.
7. Test the active noise System on the ramp prior to each use. If there is any malfunction (squealing, humming, or oscillation), the power should be turned off and the headset used conventionally. Minor humming or oscillation can usually be stopped by applying light pressure to the earcup, or installing a fresh battery.

## Supplemental instructions for Flightcom model 4DX & 5DX Applies to stereo headsets having only one volume control

1. Flightcom 4DX and 5DX headsets are wired in a different manner than most other headsets. Most headsets have the audio(+) wire attached to the volume control, where the audio(+) will divide into 2 wires, audio RIGHT and LEFT as shown in Fig. 2, page 5.
2. In the 4DX and 5DX models the audio (-) ground wire attaches to the volume control, and then one wire goes to each speaker. The 2 audio (+) wires each go directly to a speaker and do not pass through the volume control (yellow = right side; blue = left side). To install the anr modules into these headsets the wiring must be altered slightly so that the volume control operates on the audio (+) circuit.
3. To accomplish this, the ground wire should be disconnected from the volume control.

*Note: when disconnecting wires from the volume control, don't disconnect any wires directly from the volume control terminal. Leave the original wires attached to the terminals; working with them "as is" will be easier.*

4. Next, the audio (+) wires should be disconnected (de-soldered) from the speakers. Now solder the yellow wire to the volume control by attaching it to the original single black wire. The other 2 wires exiting the volume control are now the audio (+) wires and each will supply audio to a module. Disregard the blue wire and do not attach it to anything, but trim the exposed bare wire to reduce the possibility of a short. This method will convert the headset to mono, but will not affect the fidelity of the audio. Separation of channels does not enhance audio quality.
5. If you wish to retain the stereo feature of your headset, you must install a second volume control in the opposite earcup. After installation of the second volume control, solder each audio (+) wire to the corresponding volume control (yellow wire to left volume control, blue wire to right volume control). The blue wire must solder to the crossover cable (use green wire) and then will solder to the right side volume control.
6. Model 5DX headsets have a printed circuit board in the left earcup. This circuit board is your boom mic amp and filter. Do not change any wiring attached to this circuit board. However, the board will prevent installation of the anr module and must be re-positioned. This requires removal of the deepest piece of form insulation, and shifting the board so that it lays as deeply as possible in the earcup.
7. After finishing this supplemental wiring change (whether mono or stereo), return to page 8, section B to complete hook-up of the 9v+ wires.

*NOTE: If you do plan to install an additional volume control, we recommend that you complete the installation in mono mode, and consider installing the second volume control at a later date. We usually have volume controls/knobs in stock and the second volume control can be installed at a later date with minimum rework.*

*(continued from page 11)*

8. Life of a high quality 9V battery should be approximately 15-20 hours. To guard against accidentally leaving power on, unplug the power cable from battery case when unit is not in use. An optional auto shut-off battery case is available which will automatically turn the power off after 4 minutes of inactivity.
9. The active noise reduction modules require a very stable power supply. Using cheaper 9V batteries will not damage the system, but will cause malfunctions. We recommend Dura-Cell or Energizer.
10. **Do not attempt to power the anr modules directly from your aircraft electrical System** without using our panel mount power unit. The voltage spikes and background static from most aircraft will soon damage the very sensitive integrated circuits in the modules. Our panel mount power unit has a .25 amp fuse and dual voltage regulators.
11. A continuity tester is very helpful, and is usually required to trace a short or broken wire. They are available for under \$15.
12. **Do not insert any material** into the modules, such as the original cloth inserts or ear covers, foam rubber, etc., **except for the black and white oval fabric pieces provided.**

**For free technical assistance call 806-358-6336  
Weekdays from 9:00 A.M. to 5:00 P.M. (Central Time).**

Revision 03-31-15



## Limited Warranty

This product is warranted to be free from defects in materials or workmanship for one (1) year from the date of purchase. Within this period, HEADSETS, INC. will at its Sole option, repair or replace any component which fails in normal use. Such repair or replacement will be made at no charge to the customer for parts and labor; provided, however, that the customer shall be responsible for cost of shipping to HEADSETS, INC... This warranty does not cover failure due to abuse, misuse, accident or unauthorized alteration or repairs. HEADSETS, INC. assumes no responsibility for special, incidental, punitive or consequential damages, or loss of use.

THE WARRANTIES AND REMEDIES CONTAINED HEREIN ARE EXCLUSIVE, AND IN LIEU OF ALL OTHER WARRANTIES AND REMEDIES EXPRESSED OR IMPLIED, INCLUDING ANY LIABILITY ARISING UNDER WARRANTY OF MERCHANTABILITY OR FITNESS FOR A PARTICULAR PURPOSE, STATUTORY OR OTHERWISE. THIS WARRANTY GIVES SPECIFIC LEGAL RIGHTS WHICH MAY VARY FROM STATE TO STATE.

To obtain warranty service, return the unit along with a brief note indicating the nature of the problem. Include your full name, address, and daytime phone number. Ship the unit in a box only (no padded envelopes), insured and freight prepaid to HEADSETS, INC., 2320 Lakeview Drive, Amarillo, Texas 79109

**Active Headsets**  
INCORPORATED

[www.headsetsinc.com](http://www.headsetsinc.com)

E-mail: [orders@headsetsinc.com](mailto:orders@headsetsinc.com)

Phone: 806-358-6336 • Fax: 806-358-6449  
2320 Lakeview Drive • Amarillo, TX 79109